

# CM 76B

# serie performance

## Gru idraulica a montaggio rapido

Hydraulic crane with quick assembling  
Grue hydraulique à montage rapide  
Hydraulischer Schnellmontagekran  
Grúa hidráulica de montaje rápido

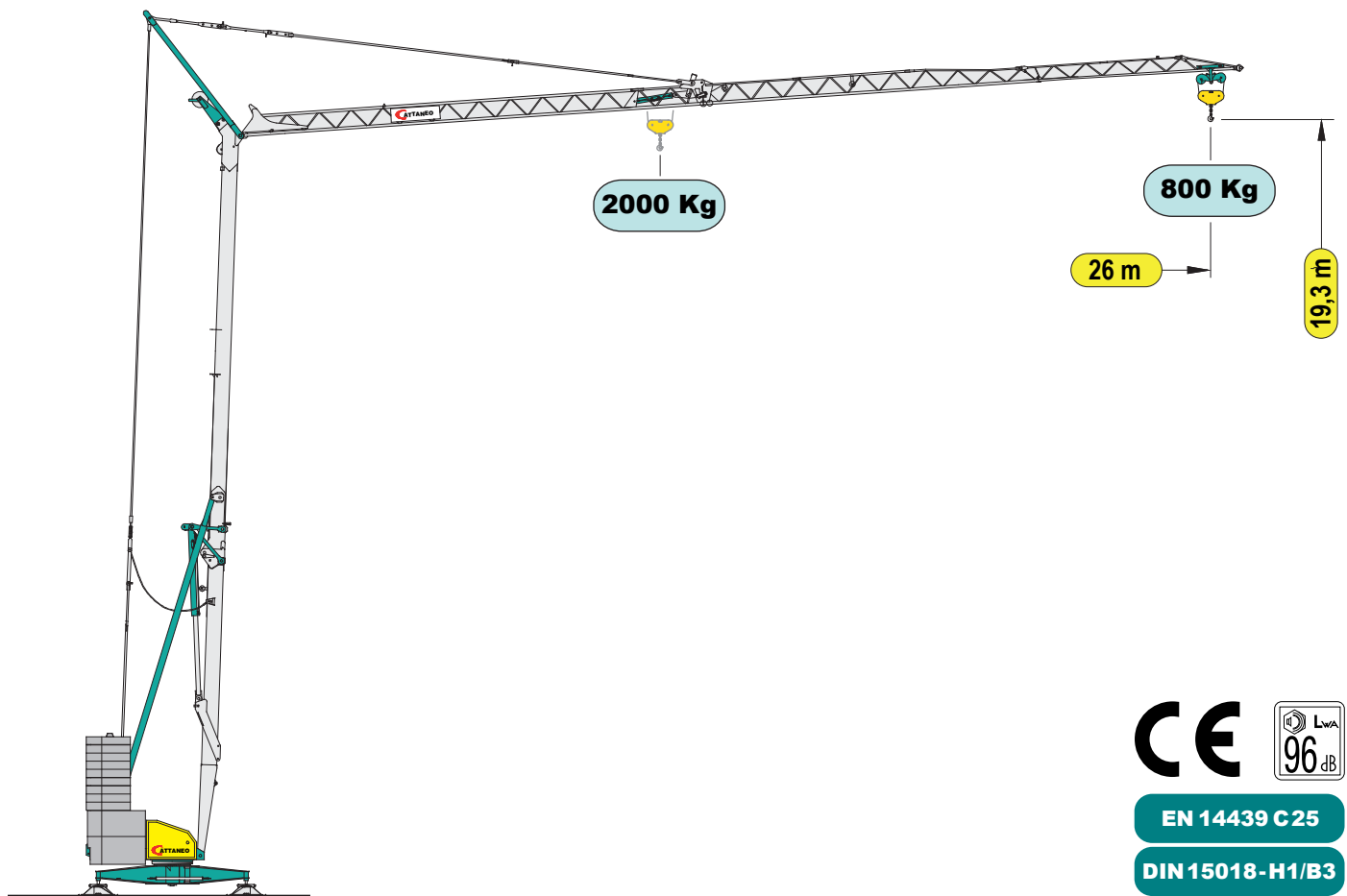

**PROGETTO:** Ufficio Tecnico LUIGI CATTANEO SpA  
**COSTRUZIONE:** Stabilimenti LUIGI CATTANEO SpA

# CATTANEO

Luigi Cattaneo S.p.A.  
via Trieste 14 - 20020 Magnago (MI) Italia  
tel. +39 331 657132 - fax +39 331 305460  
www.cattaneogru.it



## Prestazioni - Performances - Prestations - Leistungen - Prestaciones

kVA		230V - 50Hz			230V - 50Hz (6) kVA			400V - 50Hz		
		1°	2°	3°	1°	2°	3°	1°	2°	3°
inverter	kW/g/min 7,5/1400	m/min	5	18 (12)	26 (18)	m/min	5	18 (12)	40 (32)	
		kg	2.000	1.000	600	kg	2.000	2.000	600	
		m/min	5	18	40	m/min	5	18	40	
		kg	2.000	2.000	600	kg	2.000	2.000	600	
inverter	2,2/1400	m/min			30 - 35	m/min			20 - 40	
inverter	2,2/1400	g/min				g/min			0,4 - 0,9	

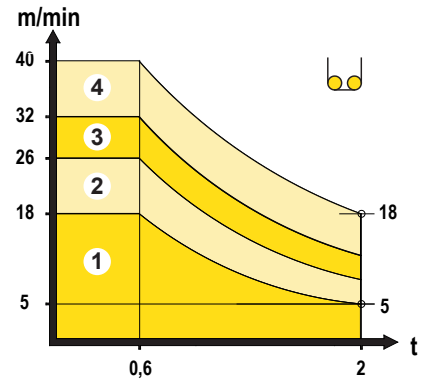

## Contrappeso in lastre di cemento armato - Ferro-concrete ballast slabs Contrepoids en plaques de béton armé - Gegenballast aus Stahlbetonplatten - Lastre en hormigón armado

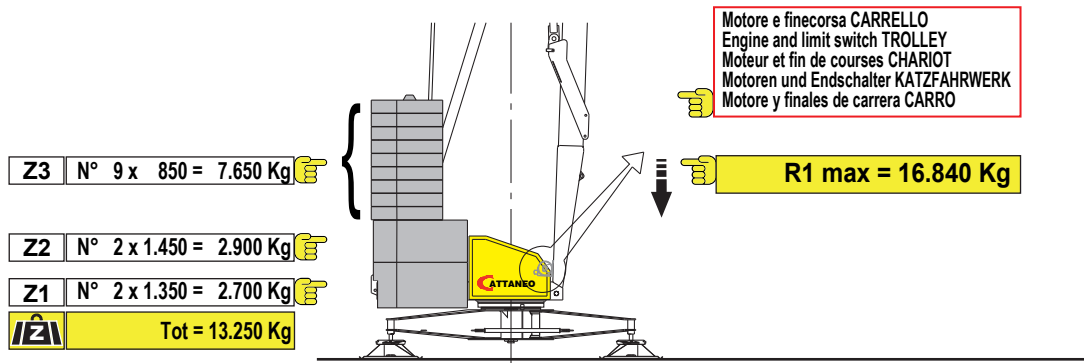

## Trasporto - Transport - Transport - Transport - Transporte

