

# BOMAG

## REVERSIBLE VIBRATORY PLATE BPR 65/70 D

### PERFORMANCE DATA

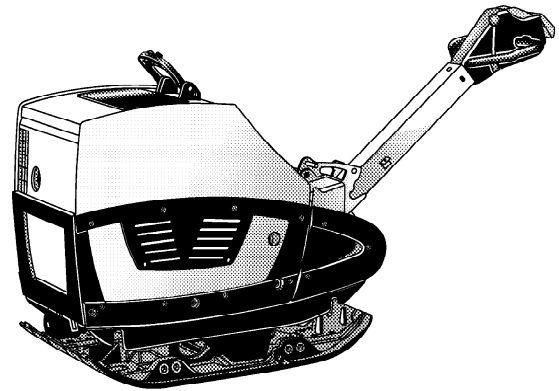

Machine type	Compaction output (m <sup>3</sup> /h) at recommended soil layer thicknesses			
	Rock fill	Gravel, sand	mixed soil	Silt, clay
BPR 65/70 D	39-52	50-66	39-52	33-44

# BOMAG

# Technical Data

## Shipping dimensions in m3

**BPR 65/70 D**

1,133

## Standard Equipment

- Fully closed engine protection hood made of high-strength grain-refined steel
- Electric starter with warning buzzer and safety switch off ignition
- Hydraulic travel lever adjustment with servo function
- 4-times supported, low-vibration steering rod
- Height adjustable steering rod
- Steering rod lockable in transport and working position
- Vibration and throttle regulation on the steering rod
- Steering rod with reversing protection
- Highly wear resistant base plate with reinforced edges
- Fully protected V-belt
- Lifetime lubricated vibration bearings
- Reinforced centrifugal clutch
- Automatic shutdown at low oil level
- Large-volume dry air filter with cyclone-type precleaner
- Safety crank-handle for emergency starting
- Multi-functional, foldable single-point lifting facility
- Working width with wear strips 700mm

## Optional Equipment

- Tool kit
- Special painting
- Hour meter

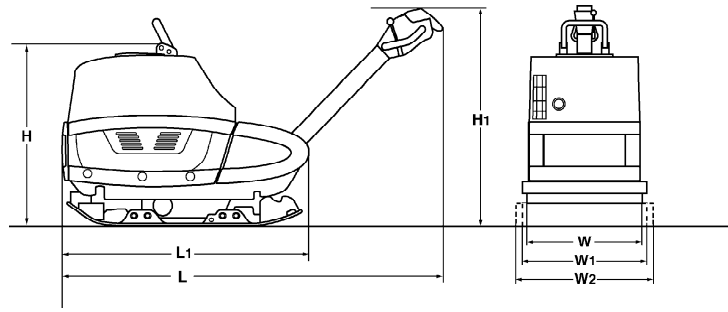

## Dimensions in mm

**BPR 65/70 D**

H	H1	L	L1	W	W1
870	1030	1860	980	550	700

## Technical Data

### Weights

Operating weight CECE (W)	kg	556
Operating weight CECE (W1)	kg	575
Basic weight	kg	570

### Dimensions

Basic working width	mm	700
Working width without extension bars (W)	mm	550
Lowest passing height	mm	870

### Driving Characteristics

Working speed, max.	m/min	28
Max. gradeability (depending on soil conditions)	%	35

### Drive

Engine manufacturer	Hatz	
Type	1D 81 Z	
Cooling	air	
Number of cylinders	1	
Performance ISO 9249	kW	9,8
Speed	min-1	2.700
Drive system	mech.	
Fuel	diesel	

### Exciter system

Frequency	Hz	67
Centrifugal force	kN	69

### Capacities

Fuel	l	10
------	---	----

Technical modifications reserved. Machines may be shown with options.

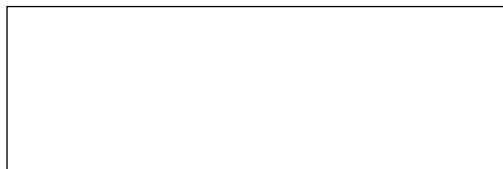

PRE 690 36 001

150604 Sa

**BOMAG**  
 Hellerwald  
 D-56154 Boppard  
 P.O. Box 5162  
 Tel. (0)6742 - 1000  
 Fax (0)6742 - 3090  
 Fax (0)6742 - 3090

# BOMAG